

OPERATION & MAINTENANCE INSTRUCTION MANUAL

PRESSURE SWITCH

General Description

The 811-PS series pressure actuated switches are designed for the detection of a water-flow condition in automatic fire sprinkler systems of particular designs such as wet pipe systems with alarm check valves, dry pipe, pre-action, or deluge valves. The 811-PS-420-1, 811-PS-10100-1, 811-PS-10200-1 containing one set of SPDT contact and 811-PS-420-2, 811-PS-10100-2, 811-PS-10200-2 containing two sets of SPDT contacts. Cover incorporates tamper resistant fastener that requires a special key for removal. One key is supplied with each device.

**CAUTION!**

Do not use in potentially explosive atmospheres. Do not leave unused wires exposed.

Specifications

Maximum Service Pressure: 300 psi

Pressure Range:

811-PS-420-1, 811-PS-420-2: 4-20 psi

811-PS-10100-1, 811-PS-10100-2: 10-100 psi

811-PS-10200-1, 811-PS-10200-2: 10-200 psi

Factory Setting:

811-PS-420-1, 811-PS-420-2: 4-8 psi

811-PS-10100-1: operates at decreasing pressure at 30 psi

811-PS-10100-2: operates in increasing pressure at 50 psi and decreasing pressure at 30 psi

811-PS-10200-1: operates at decreasing pressure at 110 psi

811-PS-10200-2: operates in increasing pressure at 130 psi and decreasing pressure at 110 psi

Approximate Differential:

811-PS-420-1, 811-PS-420-2: 3 psi throughout range

811-PS-10100-1, 811-PS-10100-2: 3 psi at 10psi & 6 psi at 100 psi

811-PS-10200-1, 811-PS-10200-2: 3 psi at 10psi & 9 psi at 200 psi

Contact Ratings:

10A at 125/250VAC, 2.5A at 30VDC

Operating Temperature Range: -40°C-60°C

Pressure Connection: 1/2" NPT Male

UL Listed and FM Approved.

Operation

As pressure changes, a diaphragm actuates 1 or 2 snap action switches. The pressure switch actuation is determined by adjustment settings.

OPERATION & MAINTENANCE INSTRUCTION MANUAL

PRESSURE SWITCH

Installation

1. The device should be mounted in the upright position. Locate it where vibration, shock, and mechanical loading are minimal. The overall dimensions see Fig. 1.
2. Mount the device directly to the line via the 1/2" NPT pressure connection. The use of Teflon pipe sealant tape is recommended. Be sure the fitting is tight enough to prevent leaks.
3. Tighten the device using a wrench on the flats of the device.

Wiring Instructions

Remove the tamper resistant screw with the special key. (Removal key is enclosed with pressure switch)

Run wires through an approved conduit connector and fix the connector to the device.

Connect the wires to the appropriate terminal connections for the service intended (see Fig. 2).

Adjustment to Factory Setting

Both 811-PS-420-1 and 811-PS-420-2 devices are pre-adjusted at the factory to alarm at 4–8 psi on rising pressure. Pressure switch settings may be adjusted in the field to obtain a different pressure alarm response from 4 psi to 20 psi. One full rotation changes the point setting by approximately 1.6 psi for 811-PS-420. The factory setting of the 811-PS-10100 series and 811-PS-10200 series device see Tab.1. One full rotation changes the point setting by approximately 11 psi for 811-PS-10100 and 22 psi for 811-PS-10200.

1. Install pressure switch as stated in "INSTALLATION" portion of instruction manual. Attach pressure test source to system.

Table 1 Factory Settings

Model	Factory Settings (psi)		
	Fall (Low Switch)	Nominal	Rise (Hi. Switch)
811-PS-10100-1	30	40	—
811-PS-10100-2	30	40	50
811-PS-10200-1	110	120	—
811-PS-10200-2	110	120	130

2. Rotate adjustment wheel (clockwise to increase pressure) and retest until switch trip point is at the desired pressure setting. Align the upper surface of the adjusting nut to the scale line of target pressure. See Fig. 1.

3. Retest the set point several times to ensure accuracy of setting.

Fig. 1 Dimensions

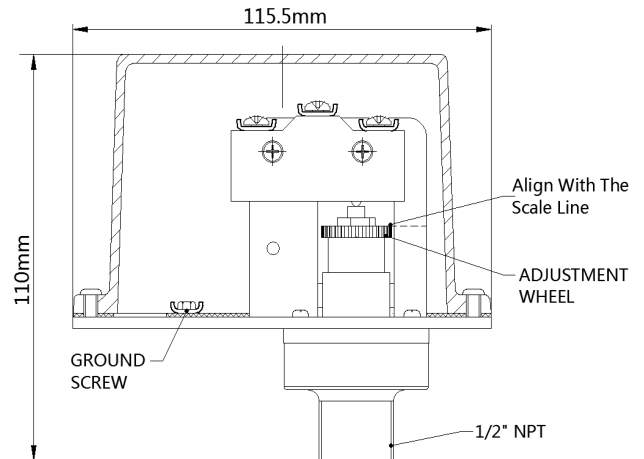

OPERATION & MAINTENANCE INSTRUCTION MANUAL

PRESSURE SWITCH

Fig.2 Typical Connections

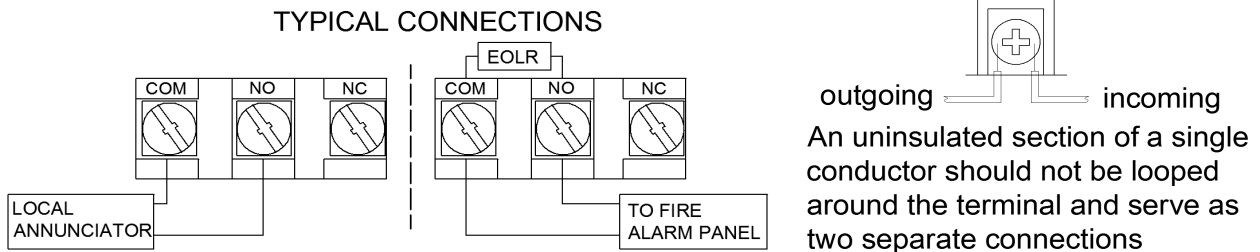

NOTE:

The assembly is not field replaceable. Do not attempt to disassemble these parts. Carefully consider the following factors when specifying and installing Pressure Switches. Always refer to the Installation Instruction for specific recommendations on individual devices before installing the unit.

Electrical ratings stated in literature and on nameplates should not be exceeded.

Overload on switch can cause failure on the first cycle. Always wire devices according to national and local electrical codes.

Install units away from shock and vibration. Proper electrical fittings should be used to prevent moisture from entering the enclosure via the conduit.

Test all devices for proper operation after initial installation. Perform preventive maintenance and periodic testing.

Do not tighten by grasping the switch enclosure. Use wrenching flats on the bushing only.

Do not mount unit where ambient temperatures will exceed published limits.

Avoid impact or mechanical loading.