

836 Series Cast Iron Wafer Style Check Valve

FEATURES

- CAST IRON BODY
- SINGLE DISK
- STAINLESS STEEL 316 SPRING & DISK
- SIZES 2" - 12"

TEST PRESSURE

- SHELL: 250 PSI
- SEALING: 200 PSI
- WORKING PRESSURE: 200 PSI



COMPONENTS

BODY PART	MATERIAL
BODY	CAST IRON ASTM A126B
DISK	SS304
SEAL RING	VITON
HANGER	SS304
SPRING	SS304
AXLE	SS416

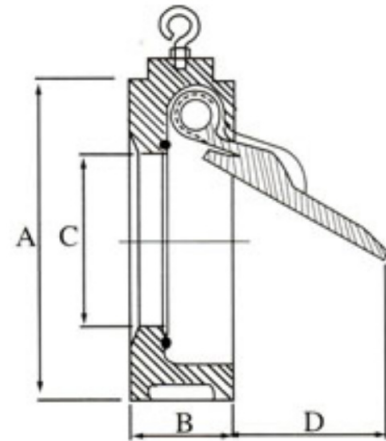

DIMENSIONS

(INCHES)

SIZE	A	B	C	D	WEIGHT (LB)
2"	4.02	1.75	1.30	1.14	3.97
2 1/2"	4.76	1.89	1.85	1.18	5.29
3"	5.28	2.01	2.05	2.20	7.05
4"	6.77	2.24	2.99	2.95	11.90
5"	7.64	2.50	3.74	3.74	16.09
6"	8.66	2.76	4.76	4.49	20.28
8"	10.91	2.87	6.61	6.14	32.19
10"	13.27	3.11	7.64	7.36	52.03
12"	16.02	3.39	9.49	8.74	75.84